

# Crystalline Silicon PV Module Installation Manual

## 1. Introduction

- 1.1 Purpose
- 1.2 Limitation of Liability
- 1.3 Precautions for Installation

## 2. Safety

- 2.1 General Safety
- 2.2 Installation Safety

## 3. Mechanical Installation

- 3.1 Installation Condition
- 3.2 Installation Methods

## 4. Electrical Installation

- 4.1 Installation Condition
- 4.2 Grounding

## 5. Maintenance

## 1. Introduction

### 1.1 Purpose

This document provides detailed instructions and valuable safety information regarding the installation, electrical connection, and maintenance of following Chint Solar Crystalline Photovoltaic modules:

CHSM6608M	CHSM6610M	CHSM6610M(BL)	CHSM6610M(FR)
CHSM6612M	CHSM6610P	CHSM6610P(BL)	CHSM6610P(BF)
CHSM6610P(FR)	CHSM6612P	CHSM6612P(FR)	
CHSM6608M/HV	CHSM6610M/ HV	CHSM6612M/HV	
CHSM6610P/HV	CHSM6612P/HV		

All the instructions should be read and understood before installation. The installers should be trained and conform to all safety precautions in this guide when installing the module. Keep this guide in a safe place for further reference.

### 1.2 Limitation of Liability

Because the use of this manual and the conditions or methods of installation, operation, use and maintenance of photovoltaic (PV) products are beyond Chint Solar's control, Chint Solar does not afford the responsibility and expressly disclaims liability for loss, damage, or expense arising out of or in any way connected with such installation, operation, use or maintenance. Chint Solar reserves the right to change the manual without prior notice.

### 1.3 Precautions of Installation

#### 1.3.1 Module's unpack and transfer

- a) When the whole pallet of modules are delivered to the site and unloaded, make sure the safety of the module especially if it needs to be lifted in the roof projects. Put it into the protect device and then lift it to the roof in case of bumping against the wall during the lifting process.
- b) Firstly, tear the stretch film, then move away the top cover after cutting off each module packing strip while unpacking. Two operators work as a group, grasp the module frame tightly in the same direction and take out the module one by one. It is a must that the operators rive the adhesive tape of the fixed module one by one, rive one piece and then take out one piece of module. We don't allow to rive all the adhesive tape one time in case that the whole pack topples and falls down. The whole process must be taken very gently.

Don't collide with any hard object or let any parts of the frame touch and drag on the ground.

- c) After unpacking the modules should be installed that day as far as possible. It's recommended to take the right amount of modules according to the progress of the project every day. Due to the modules piling on the ground after unpacking, in case of heavy rain and other inclement weather which has the potential risk to be a long soak in water can affect product reliability, such as typhoons and other modules in case of inclement weather is not installed which may be torn away. If the users need to store modules before installation, do not open the package, the goods should be stored in a room temperature, dark, dry and ventilated place.

### 1.3.2 Module's Stack

- a) When a module is taken out of the box, cardboard bedding below should be applied, in order to avoid contacting cement surface / ground hard metal or steel tile shocked collision friction scratch.
- b) When stacking modules, it needs to be stacked neatly in the horizontal plane, under the condition of the glass facing down and the back way piled up, while the cardboard bedding need to be underside the modules. If the modules will be installed on the rooftop, the number of each stack is suggested no more than 20. In case of the poor load-bearing capacity, it's recommended that each stack number is no more than 10. During the whole process, the installation tools and other objects are avoided to be on the module surface.
- c) If the modules are requested to be classified by current, the handling personnel are required to carry out of the level of the current and make a mark separately according to the power on the list. (e.g. 270W-L, identifies the modules of the packaging according to the power on the list, indicating a low current position; 270W-H, compared to high current position). Usually, the same series of modules in the same current position are required in accordance with the system design requirements.
- d) If the modules are color-coded and marked the corresponding logo on the carton due to the customer requirements, when modules are taken out and stacked, they should be labeled to avoid confusion. Usually the same row or the same square have the same color according to the system design requirements.
- e) Due to the complexity and difference of the construction site, these precautions may not cover all items, please refer to the specific construction standards.

## 2. Safety

### 2.1 General Safety

- 2.1.1 Consult and follow local codes and other applicable laws concerning required permitting as well as installation & inspection requirements, rules, and regulations.
- 2.1.2 PV modules should be installed and maintained by qualified personnel.
- 2.1.3 Use the same performance modules within a given series.
- 2.1.4 Follow all safety precautions of all components used in the system.
- 2.1.5 Do not shade portions of the PV module surface from the sun for a long period of time. The shaded cell may become hot (hot spot phenomenon), which can result in solder joints peeling off.
- 2.1.6 Do not clean the glass surface with chemicals.
- 2.1.7 Do not drop the PV module or drop objects onto the PV module.
- 2.1.8 Do not concentrate sunlight on the modules or panels.
- 2.1.9 Do not attempt to disassemble the modules, and do not remove any attached components from the modules.
- 2.1.10 Do not scratch or hit at the back sheet, the glass, the terminal box. Do not pull the cables or touch them with bare hands.
- 2.1.11 Do not drill holes in the frame or scratch the insulating coating of the frame.
- 2.1.12 Keep the PV module packed in the carton until installation.
- 2.1.13 Do not use modules near equipment or in places where flammable gases may be generated.
- 2.1.14 Do not use modules in an environment with aliphatic, aromatic, phenols, ketones, halogenated substance or mineral oil, which may corrode the junction box by chemical attack.

### 2.2 Installation Safety

- 2.2.1 Wear protective head gear, insulating gloves, safety shoes, and insulated tools when installing the modules.
- 2.2.2 Do not install the modules in rain, snow, or otherwise wet or windy conditions.
- 2.2.3 Completely cover the PV module surface with an opaque material during PV module installation and wiring to prevent accidental charge buildup.
- 2.2.4 Plug in connectors tightly when working on wiring.
- 2.2.5 Due to the risk of electrical shock, do not perform any work if the terminals of PV module are wet.
- 2.2.6 Do not touch the terminal box and the end of output cables (connectors) with bare hands.

- 2.2.7 Do not unplug the connector under load.
- 2.2.8 Do not work alone.
- 2.2.9 Wear a safety belt if working far above the ground.
- 2.2.10 Do not wear metallic jewelry, which can cause electric shock, while installing or troubleshooting the PV system.
- 2.2.11 Follow the safety regulations for any and all other system components, including wires, connectors, charging regulators, batteries, inverters, etc.
- 2.2.12 Do not expose wires to direct sunlight. Use UV-resistant cable.
- 2.2.13 Do not damage the surrounding PV modules or mounting structure when replacing a PV module.
- 2.2.14 Do not change any PV module components (diode, junction box, plug connectors, etc.).
- 2.2.15 Maximum reverse current is 20.25A for module with 6 inch cells. Application of the blocking diode and fuse in the combiner box are recommended for reverse current protection when more than two strings are connected in parallel.
- 2.2.16 A certain gap is maintained between the PV module and the mounting surface to prevent the mounting surface touching the junction box.
- 2.2.17 Standing on the solar PV module is forbidden and also prohibit installation tools or other objects hitting surface of the solar PV module.
- 2.2.18 The solar modules are recommended to be installed over a fireproof and insulating roof covering when installed on a roof.
- 2.2.19 PV cable connection cannot be too tight, it is recommended that the connector and the backsheet have a certain gap.
- 2.2.20 Region for sand blown, in order to avoid the sand into the connector, we suggest to short circuit module connectors before installation; If into the grains of sand, may cause internal live parts wear and tear, so there are some electrical safety hidden trouble.

### 3 Mechanical Installation

#### 3.1 Installation Conditions

- 3.1.1 Extreme environment temperature:  $-40^{\circ}\text{C}$  to  $+85^{\circ}\text{C}$
- 3.1.2 Operating temperature:  $-40^{\circ}\text{C}$  to  $+85^{\circ}\text{C}$
- 3.1.3 Maximum test mechanical load on panels (e.g., snow/wind): less than 6000/3600Pa, please refer to the detailed mounting instructions as Chapter 3.2.
- 3.1.4 Tilt Angle selection: The installation should be facing north in the southern hemisphere and facing south in the northern hemisphere.
- 3.1.5 To maintain the modules' Class C fire rating, the fire class of the roof and building materials should be higher than Class C.
- 3.1.6 To maintain the modules' fire performance type 1(for US market), it could be possible to

achieve the Class A system fire rating, with the Class A class racking system.

## 3.2 Installation Methods

### 3.2.1 Bolting through the mounting holes

All modules (excluding the double glass module) must be securely fastened with at least 4 bolts ( Figure a and Figure b). For maximum security against strong winds or heavy snow falls, all of the mounting holes are recommended to be used.

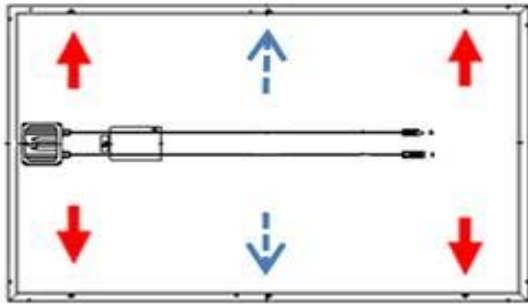

**Figure a**

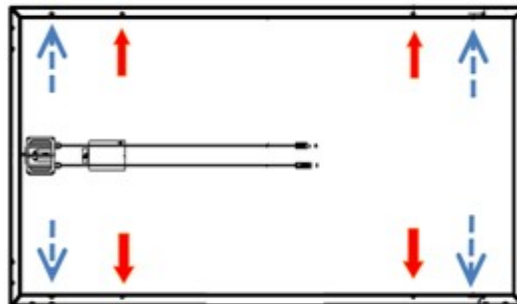
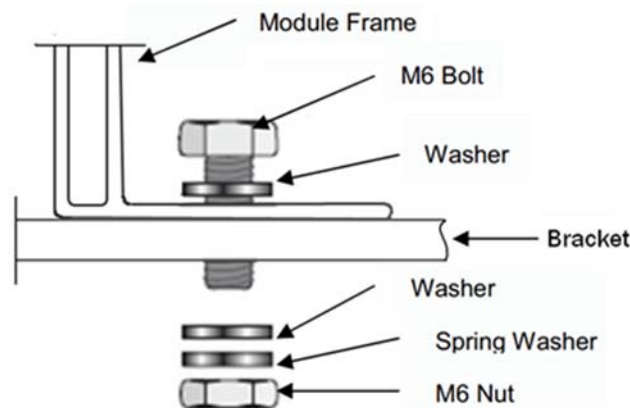

**Figure b**

Remark: As for above diagram, the solid red arrows indicate primary bolt positions; dashed blue arrows indicate positions where bolts can be added for additional support.

Bolts are inserted as described in the process below (Figure c).

- Place the module on the supporting bars underneath.
- Insert the four stainless-steel bolts (M6) through the holes (7x11.5mm) in the frame according to the Figure a & Figure b. For maximum security against strong winds and heavy snow, all available mounting holes should be used.
- Secure each bolt to the frame with stainless-steel washers, one for each side of the mounting structure; and screw on either a stainless-steel spring washer or a toothed lock washer. Finally, secure with a stainless steel nut (M6).
- The torque for tightening the nut and bolts recommended 13Nm when the property class of bolts and screws is Class 8.8.



**Figure c**

### 3.2.2 Clamping on the frame surface

### 3.2.2.1 Single glass module

Modules can be laid either across the supporting bars (Figure d & f) or parallel to the edge of frame (Figure e & g) .

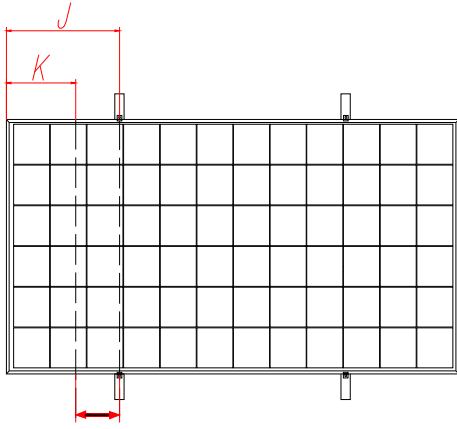

Fig d

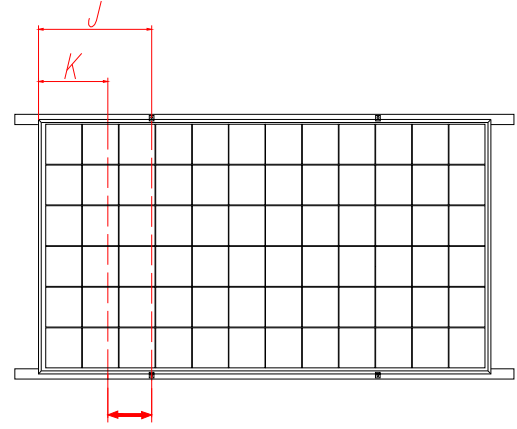

Fig e

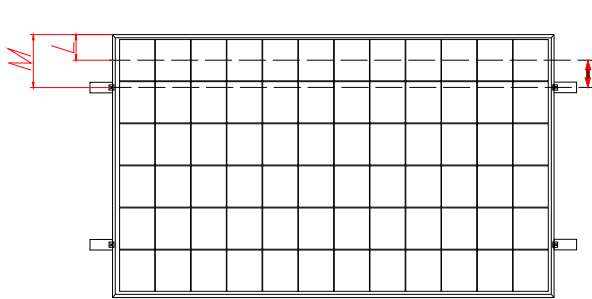

Fig f

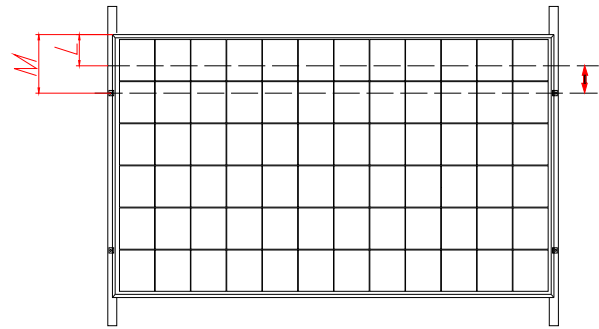

Fig g

**Remark:**

- 1) The length of supporting bars must be longer than the length of module frame, otherwise please confirm with our product team to get approval.
- 2) As for above figure d, the solid red rectangles indicate primary clamp installation positions and the center positions of long frames where clamps can be added for additional support.
- 3) Illustrations (figure d、e、f、g) of the four different methods for clamping modules on the frame with aluminum clamps. “” means the aluminum clamp’s permissible clamping range. The recommended installation position shows as below table. Note: “---” means Fig f & Fig g methods will be not suitable for the module type.

Module Series	Dimension A*B*C	J	K	L	M	Note
CHSM6610P/(FR)	1648*990*35	408	198	---	---	
CHSM6608M/(HV)	1332*990*40	328	198	---	---	
CHSM6610M/(BL)/(FR)/(HV)	1648*990*40	408	198	---	---	
CHSM6610P/(BL)/(BF)/(HV)	1648*990*40	408	198	---	---	
CHSM6612P/(HV)	1954*990*45	489	299	50	200	3.2mm glass

CHSM6612P/(FR)/M/(/HV)	1954*990*40	489	299	---	---	4.0mm glass
CHSM6612M/(/HV)	1954*990*40	489	299	---	---	
CHSM6612P/(FR)/M/(/HV)	1954*990*40	489	299	---	---	3.2mm glass
CHSM6612M/(/HV)	1954*990*40	489	299	---	---	

To fasten the module:

- Place the module on the two supporting bars (not provided). The bars should be made with stainless material and treated with an anti-corrosion process (e.g., anodic oxidation treatment) or aluminum profile. Each solar PV module needs at least four clamps to fix. Do not make the clamp contact the glass directly or make the aluminum frame deformation in the installation process, and avoid the shadow of solar PV components.
- The bar's top surface contacted with module frame should come with grooves compatible with an M8 bolt.
- If the bars do not come with grooves, holes of a suitable diameter may need to be drilled to allow bolts to be attached to the bars at the same locations as mentioned above.
- Secure each clamp by attaching plain washer, spring washer, and nut, in that order.
- Both of close-ups of Figure h, indicating the middle clamps and Figure i, indicating the side clamps for reference. Suggest the dimensions for middle clamps are:  $a \geq 40$  mm,  $b \geq 26$  mm,  $c = 8$  mm,  $d \geq 28$  mm, and  $\varnothing = 9$  mm. The torque for tightening the nut and bolts are recommended 28Nm when the property class of bolts and screws is Class 8.8.

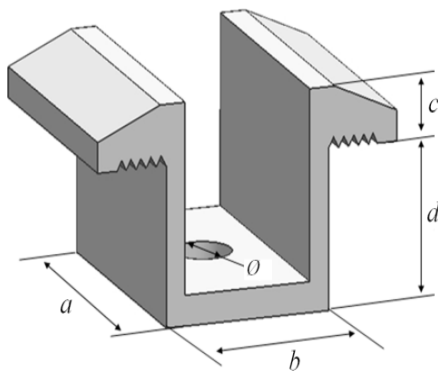

Figure h

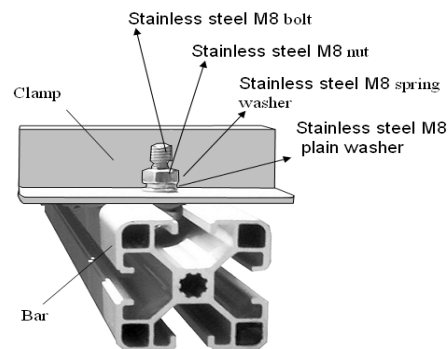

Figure i

- Especially for Figure e & Figure g mounting method, the modules may be mounted using clamps designed for solar modules refer to Figure j, the modules must be supported along the length of the edge, and should overlap the array rail by 10mm – 14mm



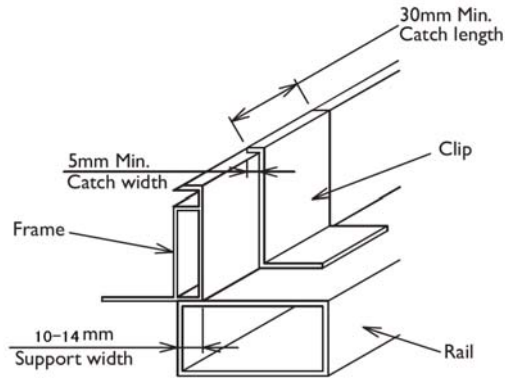

Figure j

- g) Especially for Figure f & Figure g mounting method: the recommended test mechanical load on panels is less than 3600Pa, and this method is only suitable for 45mm frame module series.

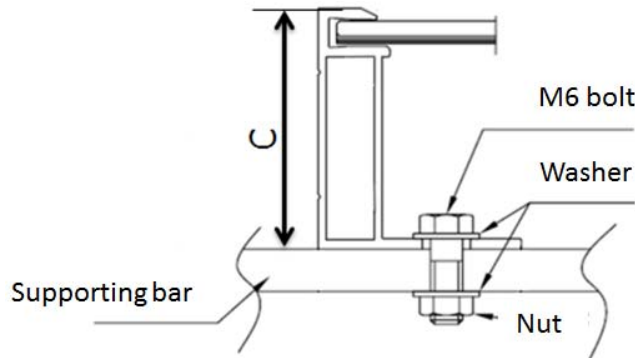

Figure k

## 4 Electrical Installation

### 4.1 Installation Condition

- 4.1.1 The electrical characteristics are within  $\pm 10\%$  of the indicated values of  $I_{sc}$ ,  $V_{oc}$  and  $P_{mpp}$  under the standard test conditions (irradiance of  $1000 \text{ W/m}^2$ , AM1.5 spectrum, cell temperature of  $25^\circ\text{C}$ ).
- 4.1.2 The maximum system voltage of all the IEC & UL standard module series is 1000V. The 1500V standard products are also available according to the requirements).
- 4.1.3 Connect quantity of modules that match the voltage specifications of the inverters used in system. Modules must not be connected together to create a voltage higher than the permitted maximum system voltage under the lowest local temperature conditions.
- 4.1.4 Under normal conditions, a photovoltaic module is likely to experience conditions that produce more current and/or voltage than reported at standard test conditions. Accordingly, the values of  $I_{sc}$  and  $V_{oc}$  marked on this module should be multiplied by a factor of 1.25 when determining component voltage ratings, conductor ampacities, fuse sizes, and size of controls connected to the PV output.

- 4.1.5 Refer to Section 690-8 of the National Electrical Code for an additional multiplying factor of 125% (80% derating) which may be applicable.
- 4.1.6 Each module (or series-connected string of modules) shall be provided with the maximum series fuse, specified 15A for the 6 inch cell module series.
- 4.1.7 Use a special solar cable and plugs for installing the PV system and make sure that all connections are safe and tight. The cable should be 4 mm<sup>2</sup> (12AWG), and able to withstand the maximum possible system open-circuit voltage.
- 4.1.8 Bypass diodes are included in module junction boxes to avoid decreased module performance in the event of shade or shelter. Please check the relevant product datasheet for the specific diodes of J-box.

## 4.2 Grounding

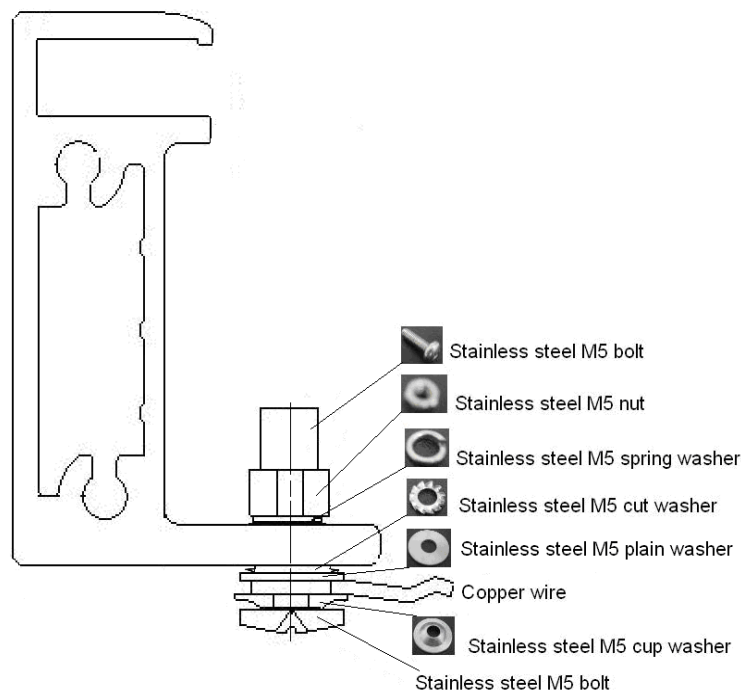

### (n) Grounding the aluminum frame with copper wire

- 4.2.1 The grounding requirements must be checked in accordance with the applicable regulations and standards before work is started.
- 4.2.2 Use the marked 5.5 mm grounding holes to ground the anodized frame. Use one M5 nut, two M5 cut washers, one M5 plain washer, one M5 spring washer, and one M5 bolt and the copper wire. All nuts, bolts, and washers are type M5 and should be made of stainless steel (Fig. (n) ).
- 4.2.3 Put the bolt through the cup washer and wrap the copper wire around the bolt. (Note that the copper wire cannot be attached directly to the aluminum.)
- 4.2.4 Put the bolt through the cut washer and then through the hole in the aluminum frame.
- 4.2.5 Add the spring washer and nut on the other side of the bolt and tighten to secure all parts. The tightening torque should be 210±20 N•cm.
- 4.2.6 Approve the use of UL-467 certified bonding and grounding devices, including Burndy

(formerly Wiley Electronics) Washer Electrical Equipment Bonding (WEEB) and similar devices, such as barbed washers, that meet the requirements of UL-467 as suitable for electrical bonding and grounding PV modules to PV mounting systems.

## 5 Maintenance

- 5.1 Regularly carry out a visual inspection for dirt, dust, bird dropping, leaves, and other detritus covering the modules.
- 5.2 If snow is present, a soft-bristled brush with soft bristles may be used to clean the surface of the modules.
- 5.3 Regular electrical and mechanical inspection by a licensed professional will keep the system safe and operating at maximum efficiency.
- 5.4 Recommended PV module Cleaned-up period

To get high output performance, PV module needs to be cleaned-up periodically as below:

- ① Normal: Minimum one time per every month; Dust wind: Right away after the dust wind;
- ② The period of the PV module cleaning shall be determined by the condition of the weather & pollution. O&M operator shall keep record of weather condition everyday with photo and data.

### 5.5 Condition of Cleaning

- 5.5.1 Use clean water or filtered water with soft type material (a sponge) to wipe the PV module. Never use chemicals on the surface of the module.
- 5.5.2 Cleaning after sunset or before sunrise is recommended for safety of O&M operator shock from heat stroke.
- 5.5.3 Do not use abrasive powder, abrasive cleaners, scrubber cleaners, polishers, sodium hydroxide, benzene, nitro-thinners, acid or alkali and other chemical substances.
- 5.5.4 Do not clean broken glass or modules with broken lines or exposed wires, as it may cause the electric shock.

CHINT SOLAR (ZHEJIANG) Co., Ltd.

Add: 1335 Bin'an Rd, Binjiang District, Hangzhou, China 310053

Tel: 86-571-5603 1888

Fax: 86-571-5603 2333

<http://www.astronergy.com>