

# PENTA<sup>+</sup> Premium<sup>TM</sup>

Incredible Power for Small Body

## 320W~335W

Monocrystalline PV Module

CHSM60M(BL)-HC Series (158.75)

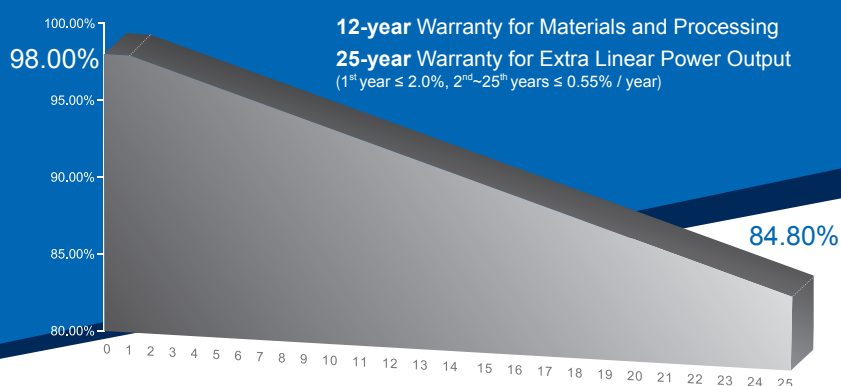

### KEY FEATURES

- OUTPUT POSITIVE TOLERANCE**  
 GUARANTEED 0~+5W POSITIVE TOLERANCE ENSURES POWER OUTPUT RELIABILITY.
- INNOVATIONAL HALF-CELL TECHNOLOGY**  
 IMPROVES THE MODULE OUTPUT, DECREASES THE RISK OF MICRO-CRACK, ENHANCES THE MODULE RELIABILITY.
- INNOVATIVE PERC CELL TECHNOLOGY**  
 EXCELLENT CELL EFFICIENCY AND OUTPUT.
- REDUCE SHADOW LOSS**  
 EFFECTIVELY REDUCES THE EFFECT OF SHADOW ON THE MODULE SURFACE.
- REDUCE INTERNAL MISMATCH LOSS**  
 REDUCES MISMATCH LOSS AND IMPROVES OUTPUT.
- THE-STATE-OF-THE-ART APPEARANCE**  
 FULL BLACK DESIGNED FOR A BETTER AESTHETIC APPEARANCE AND BUILDING INTEGRATION.
- Anti PID RESISTANCE**  
 EXCELLENT PID RESISTANCE AT 96 HOURS (@85°C /85%) TEST, AND ALSO CAN BE IMPROVED TO MEET HIGHER STANDARDS FOR THE PARTICULARLY HARSH ENVIRONMENT.

### COMPREHENSIVE CERTIFICATES



First solar company which passed the TUV Nord IEC/TS 62941 certification audit.



**ASTRONERGY**  
A CHNT COMPANY

## ELECTRICAL SPECIFICATIONS

STC rated output ( $P_{mpp}$ )*	320 Wp	325 Wp	330 Wp	335 Wp
Rated voltage ( $V_{mpp}$ ) at STC	33.68 V	33.93 V	34.17 V	34.44 V
Rated current ( $I_{mpp}$ ) at STC	9.50 A	9.58 A	9.66 A	9.73 A </td
Open circuit voltage ( $V_{oc}$ ) at STC	40.72 V	41.03 V	41.32 V	41.61 V
Short circuit current ( $I_{sc}$ ) at STC	9.98 A	10.06 A	10.14 A	10.22 A
Module efficiency	18.9%	19.2%	19.5%	19.8%
Rated output ( $P_{mpp}$ ) at NMOT	238.6 Wp	242.4 Wp	246.1 Wp	249.8 Wp
Rated voltage ( $V_{mpp}$ ) at NMOT	31.39 V	31.63 V	31.85 V	32.10 V
Rated current ( $I_{mpp}$ ) at NMOT	7.60 A	7.66 A	7.73 A	7.78 A
Open circuit voltage ( $V_{oc}$ ) at NMOT	38.28 V	38.57 V	38.85 V	39.12 V
Short circuit current ( $I_{sc}$ ) at NMOT	8.03 A	8.09 A	8.16 A	8.22 A
Temperature coefficient ( $P_{mpp}$ )	- 0.34%/°C			
Temperature coefficient ( $I_{sc}$ )	+0.04%/°C			
Temperature coefficient ( $V_{oc}$ )	- 0.27%/°C			
Nominal module operating temperature (NMOT)	44±2°C			
Maximum system voltage (IEC/UL)	1000V <sub>DC</sub>			
Number of diodes	3			
Junction box IP rating	IP 68			
Maximum series fuse rating	20 A			

\* Measurement tolerance +/- 3%

STC: Irradiance 1000W/m<sup>2</sup>, Cell Temperature 25°C, AM=1.5

NMOT: Irradiance 800W/m<sup>2</sup>, Ambient Temperature 20°C, AM=1.5, Wind Speed 1m/s

## CURVE

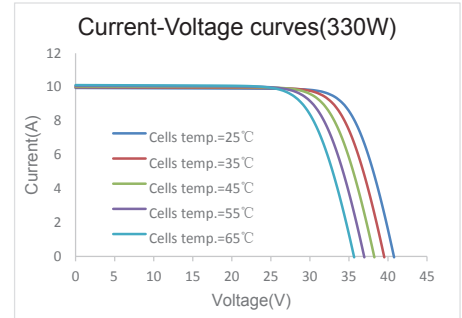
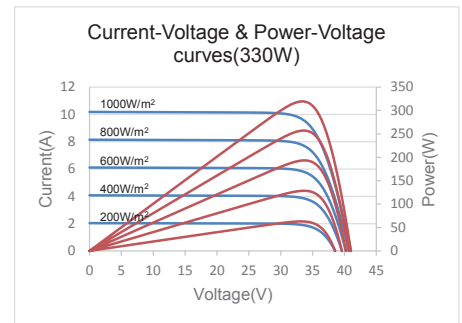

## MECHANICAL SPECIFICATIONS

Outer dimensions (L x W x H)	1692 x 1002 x 35 mm
Frame technology	Aluminum, black anodized
Module composition	Glass / EVA / Backsheet (black)
Front glass thickness	3.2 mm
Cable length (IEC/UL)	1100 mm
Cable diameter (IEC/UL)	4 mm <sup>2</sup> / 12 AWG
① Maximum mechanical test load	5400 Pa (front) / 2400 Pa (back)
Fire performance (IEC/UL)	Class C (IEC) or Type 1 (UL)
Connector type (IEC/UL)	MC4 (Stäubli) original

## PACKING SPECIFICATIONS

① Weight (module only)	19.1 kg
② Packing unit	31 pcs / box
Weight of packing unit (for 40'HQ container)	631 kg
Number of modules per 40'HQ container	806 pcs

① Tolerance +/- 1.0kg

② Subject to sales contract

① Refer to Astronergy crystalline installation manual or contact technical department.  
Maximum Mechanical Test Load=1.5×Maximum Mechanical Design Load.

## MODULE DIMENSION DETAILS

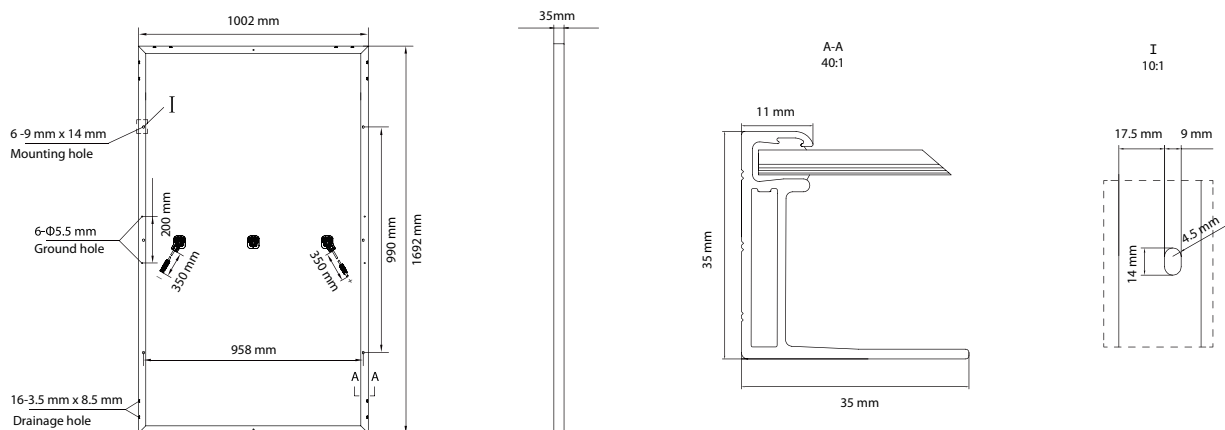

© Chint Solar (Zhejiang) Co., Ltd. Reserves the right of final interpretation. please contact our company to use the latest version for contract.